

# Battery Charging Room Accessories

## TAKING CHARGE OF YOUR CHANGING NEEDS<sup>SM</sup>

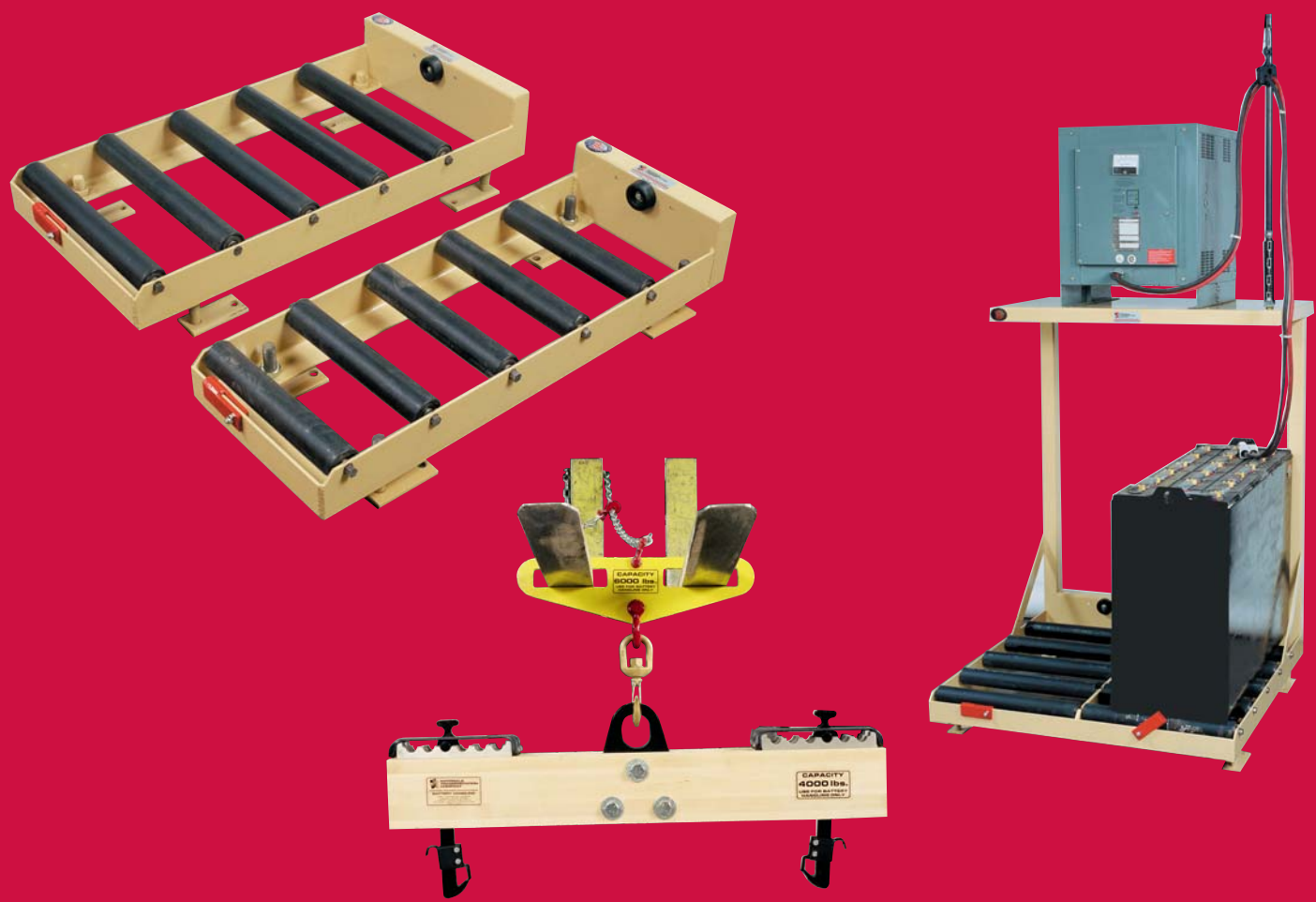

# Battery Lifting and Charger Supports



## Battery Handling Beam

Model HB-4000-SL  
Handling Beam with  
safety latch

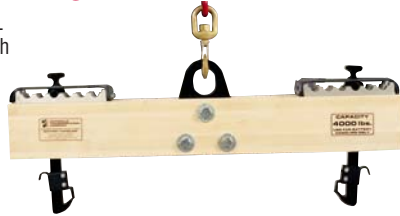

The battery handling beam offers a heavy duty non-conductive method of lifting batteries. The non-slip hook design fits snugly into most battery lifting holes. All MTC handling beams are now equipped with MTC's Posi-Latch safety mechanism.

## Fork Attachment

Model FA-6000

Used with Battery Handling Beam for battery removal

### Features

- 48" safety chain and hook
- Swivel hook with safety latch
- Fork openings – 1 5/8" x 6 1/2"
- 6000 lb. capacity

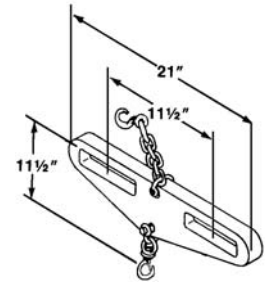

Model	Capacity	OL	Batteries	Adjustable in 3" increments*
HB-4000-SL	4000 lbs.	43"	21" to 42" long	24" to 39"
HB-6000-SL	6000 lbs.	47"	25" to 46" long	28" to 43"

\*Dimensions with hooks in vertical position.  
Each hook may be angled 1 1/2" open, or closed safely.  
All dimensions shown are nominal and subject to change.

## Wall Mounted Charger Support

Model CSW-2

One set fits  
standard chargers

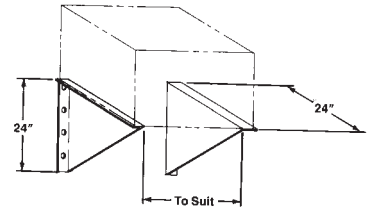

## Charger Cable Retractor

Model BCR-58H

### Features

- Molded suspender holds cables securely in place
- Oil tempered spring will not kink or take permanent set
- Snubber chain restricts spring back movement
- Rugged 5/8" threaded stud
- Each stick is fully assembled and individually boxed



## Floor Mounted Charger Support

Model	OW
CSF-24	24"
CSF-36	36"

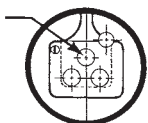

3/4" diameter

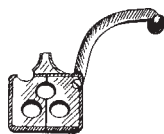

Easily opens with light finger pressure. **NO TOOL REQUIRED**



Electrical lines can then be slid into proper position.



Snap it shut and your lines are held snugly in place.

**Engineers • Designers • Manufacturers**  
[www.mtcworldwide.com](http://www.mtcworldwide.com)

Phone (254) 298-2900 • U.S. (800) 433-3110 • Canada (800) 229-5988

# Battery Stations

## Battery Station with Rollers

### Two-Compartment

Model	Roller Width	Outside Width (OW)
RS-12-2	12"	26"
RS-15-2	15"	32"
RS-18-2	18"	38"
RS-21-2*	21"	44"
RS-24-2*	24"	50"
RS-27-2	27"	56"
RS-30-2	30"	62"
RS-34-2	34"	70"

### Three-Compartment

Model	Roller Width	Outside Width (OW)
RS-12-3	12"	39"
RS-15-3	15"	48"
RS-18-3	18"	57"
RS-21-3*	21"	66"
RS-24-3*	24"	75"
RS-27-3	27"	84"
RS-30-3	30"	93"
RS-34-3	34"	105"

\*45" deep units available. Add "-45" to model number.  
To order w/o shelf add "-LCS" to model number.  
All meet OSHA requirements.  
'R' = Desired height of rollers above floor. Please specify.  
(Minimum of 5")  
Adjustable Height Plus or Minus 1 1/2".

### Battery Station with Rollers Features

- Heavy-Duty Construction
- Non-Conductive Roller Bed
- Spring Loaded Rollers
- Adjustable Legs
- Battery Safety Stops
- 800 lb. Capacity Charger Shelf
- Models For All Battery Sizes



Shown with optional Charger Cable Retractor.

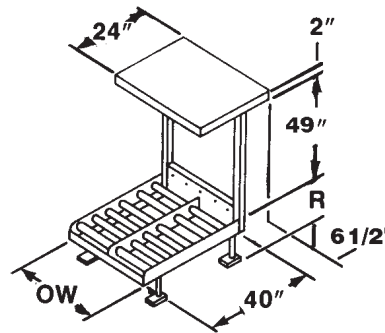

Model B-SS-21



Model B-SS-15

## Battery Service Station

Model	Roller Width	Outside Width (OW)
B-SS-15	15"	15 3/4"
B-SS-21	21"	21 3/4"

**R = roller height** Available from 5" to 14"

All dimensions shown are nominal and subject to change without notice.

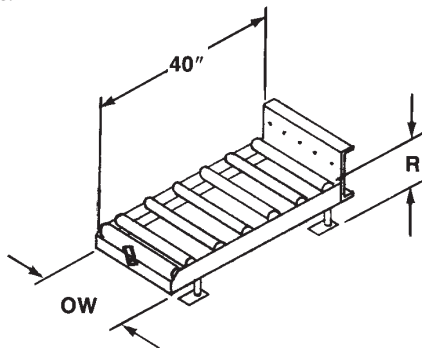

Individual specification sheet available.

### Battery Service Station

- Heavy-Duty Construction
- Non-Conductive Roller Bed
- Spring Loaded Rollers
- Adjustable Legs
- Battery Safety Stops
- 2.5" Diameter Roller

**Engineers • Designers • Manufacturers**

[www.mtcworldwide.com](http://www.mtcworldwide.com)

Phone (254) 298-2900 • U.S. (800) 433-3110 • Canada (800) 229-5988

# Battery Safety And Service Equipment

## Shower Eyewash Assembly

Model SEW-303

### Features

- Large stainless steel pull rod actuator
- Self-adjusting regulator to assure a constant, even flow
- Galvanized piping
- ABS dual stream head with pop-off covers
- Bright yellow, ABS plastic shower head for maximum visibility
- Stay-open 1 1/4" ball valve



## Battery Watering Gun

Model B

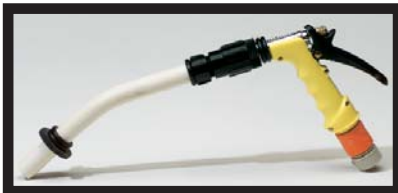

### Features

- Accurate automatic filling
- Automatic shutoff & pressure regulator
- 7/8 inch nozzle diameter
- High flow rate - 2 gallons/minute
- Attaches to any standard hose
- Insulated against short circuits

### Options

- Narrow 5/8 inch nozzle diameter
- Steeper nozzle bend
- Cone shaped nozzle
- Manually adjustable flow throttle
- Removable extension

## Battery Spill Response Kit

### Features

- Compact, lightweight design
- Easy-to-read instructions
- Replaceable components
- Single pack Nutra-Tube design
- All in one convenience
- Inspection date label



## Eyewash

Model EW-304

### Features

- Large stainless steel push plate
- Self-adjusting regulator to assure a constant, even flow
- ABS dual stream head with pop-off cover
- Rugged, bright yellow catch basin insures maximum visibility



## Safety Kit

Model SK-1

### Kit Includes:

Chemical resistant face shield with polycarbonate window. The adjustable ratchet headgear ensures a secure, comfortable fit. Acid apron is polyester double-coated with PVC. One size apron neck strap and waist ties are adjustable.



Gloves are nitrile acid resistant, with comfort curved finger and hand design.



## Battery Cleaning Kit

Model BCK-10

### Contents

- Chemicals
- Gloves
- Brushes
- Goggles



## Water De-ionizer System

Model PS-300



Safety Note: Always wear proper protection (MTC Model SK-1 or equivalent) when handling or servicing industrial batteries.

Engineers • Designers • Manufacturers

[www.mtcworldwide.com](http://www.mtcworldwide.com)

U.S. (800) 433-3110 • Canada (800) 229-5988

P.O. Box 1358 • Temple, Texas 76503 • Phone (254) 298-2900 • Fax (254) 771-0287